

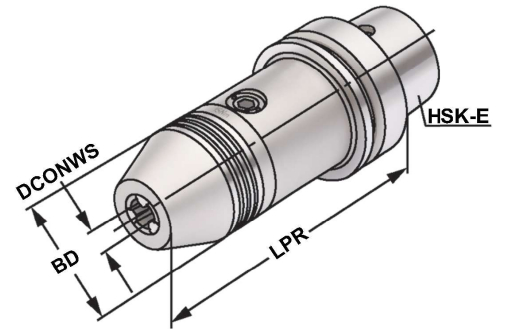

CNC-Drill chucks for clockwise and counter clockwise rotation
Mandrins de perçage CNC pour rotation gauche-droite



Verwendung:
Zur Aufnahme von Werkzeugen mit Zylinderschaft.
Application:
For mounting tools with straight shanks.
Application:
Pour le serrage d'outils avec queue cylindrique.



5

Bestell-Nr. Order no. Référence	HSK	DCONWS Spannbereich Capacity Capacité	LPR	BD	DRVS
E25.15.08	HSK-E 25	0 – 8	70,0	36	4
E32.15.08	HSK-E 32	0 – 8	75,0	36	4
E40.15.08	HSK-E 40	0 – 8	80,0	36	4
E40.15.13	HSK-E 40	1,0 – 13	119,0	50	6
E40.15.16	HSK-E 40	2,5 – 16	124,5	50	6
E50.15.08	HSK-E 50	0 – 8	80	36	4
E50.15.13	HSK-E 50	1,0 – 13	121,0	50	6
E50.15.16	HSK-E 50	2,5 – 16	126,5	50	6
E63.15.13	HSK-E 63	1,0 – 13	123,5	50	6
E63.15.16	HSK-E 63	2,5 – 16	129,0	50	6

Hinweis: Hohe Präzision und Rundlaufgenauigkeit von $\leq 0,03$ mm. Sichere Spannung des Werkzeuges durch mechanische Spannkraftverstärkung. Kein selbständiges Lösen der Spannung während der Bearbeitung bei Links- oder Rechtslauf, sowie bei Spindelstop. Spannen und Lösen mit Sechskantschlüssel.

Note: High precision and accurate concentricity of ≤ 0.03 mm. Secure gripping of the tool through mechanical amplification of the clamping force. No automatic slackening of the clamping force while machining with either clockwise or counter clockwise rotation or on spindle stop. Clamping and releasing effected by means of an Allen wrench.

Observation: Précision élevée et exactitude de circularité de $\leq 0,03$ mm. Serrage sûr de l'outil grâce à l'amplification de la force de serrage. Pas de desserrage intempestif en cours d'usinage lors de la rotation la gauche ou la droite, de même qu'en cas d'arrêt de la broche. Serrage et desserrage en utilisant un clé sur à fourche.

Lieferumfang: Ohne Spannschlüssel
Delivery: Without wrench
Livraison: Sans clé de serrage

